



Agenda

- **Merrimack Valley Incident**
- **Key regulatory changes coming from Leonel Rondon sections of the 2020 Pipeline Safety Act**

Merrimack Valley

- Region along the Merrimack River of New Hampshire and Massachusetts.

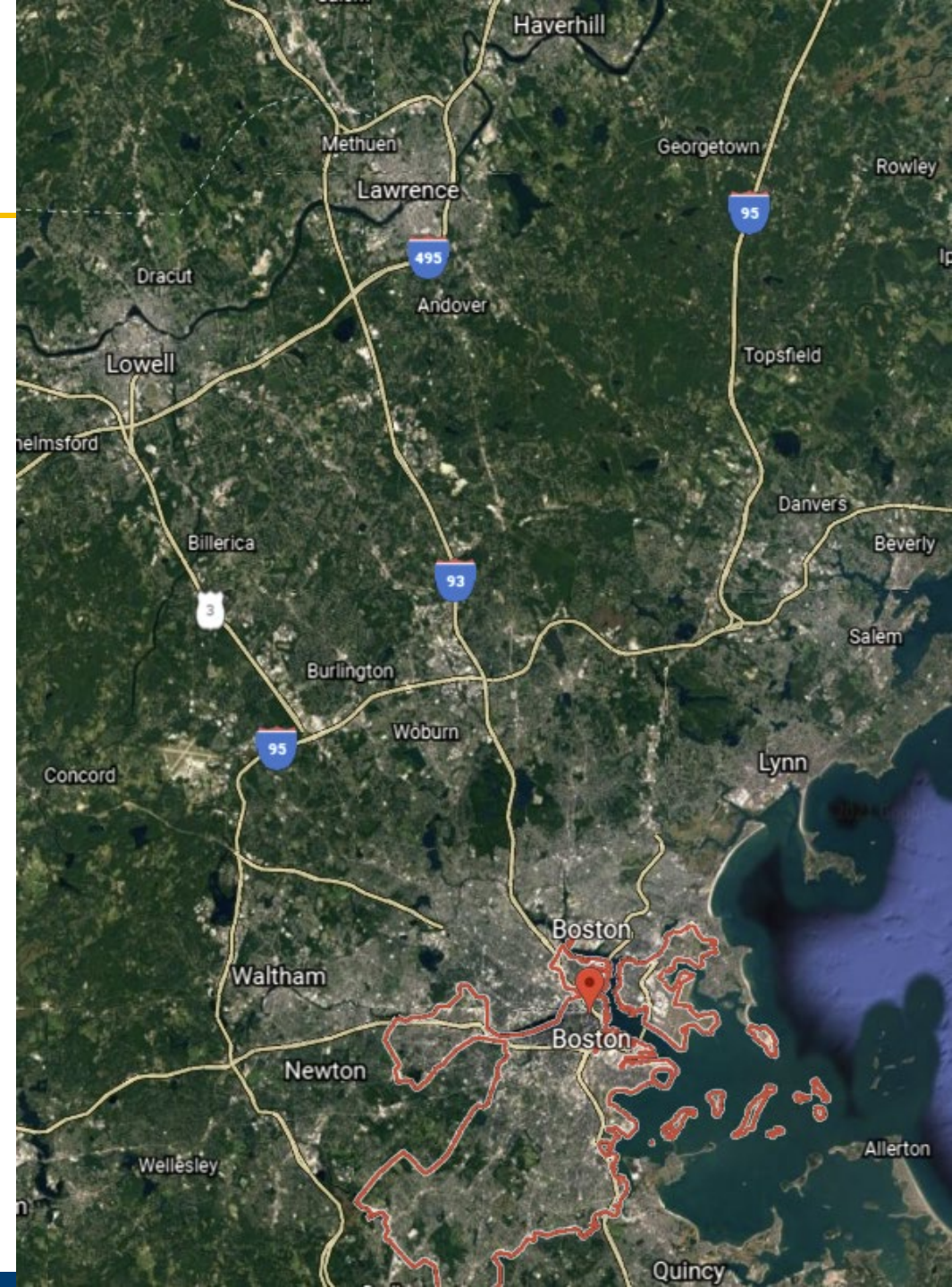

Merrimack Valley Incident

- September 13, 2018
- Affecting the towns of Lawrence, North Andover and Andover
- 1 fatality
- 22 injuries, 3 were firefighters
- Impacted over 10,000 customers
- 180 Fire Depts
- 140 Law Enforcement Agencies

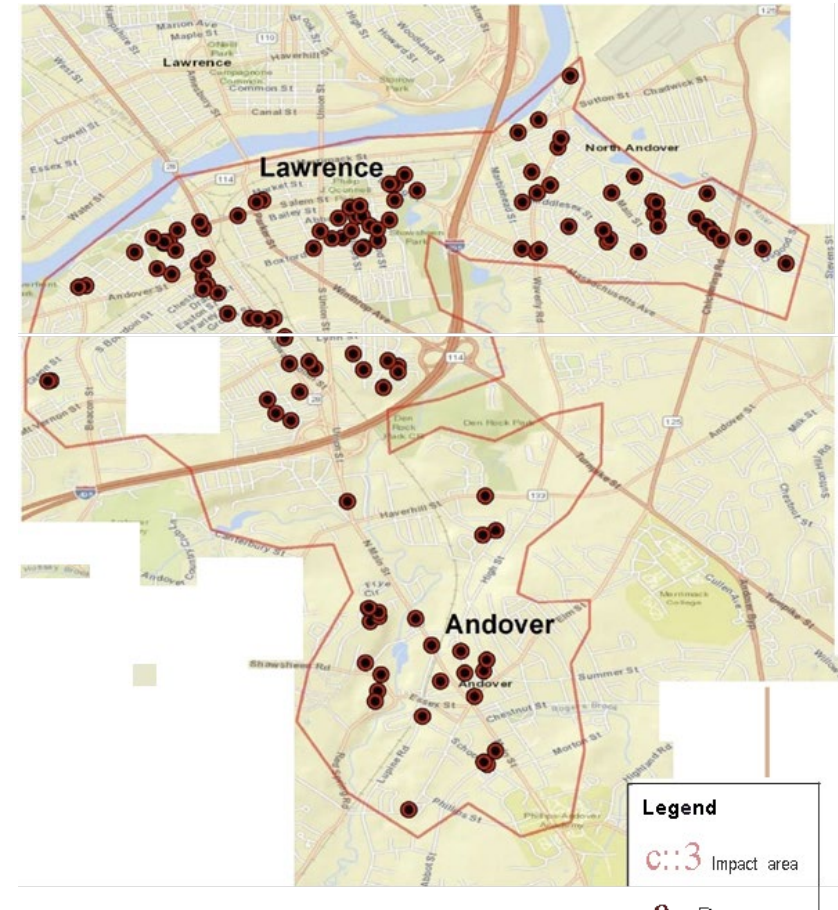

Low Pressure Gas System

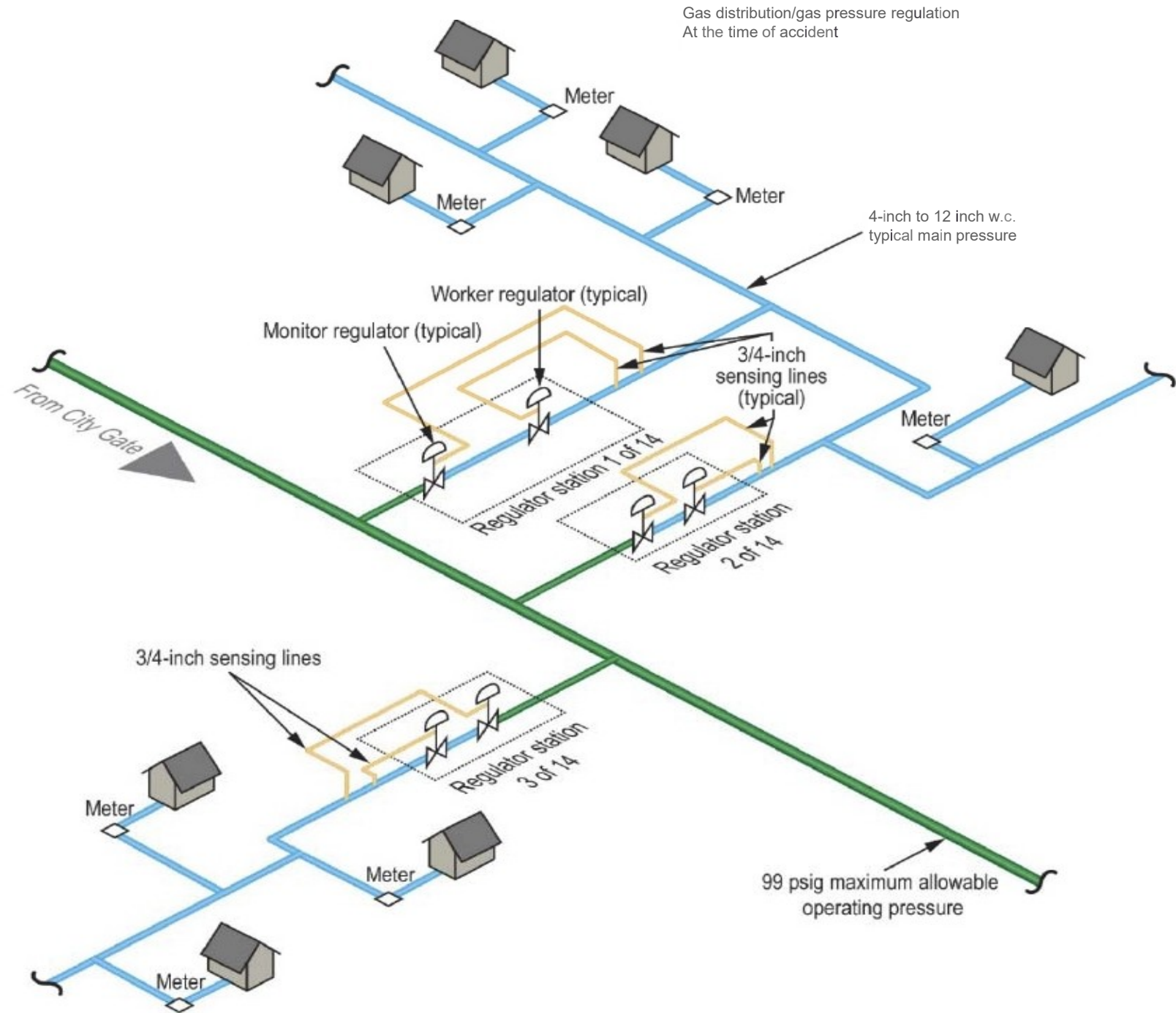

Regulatory Station Configuration

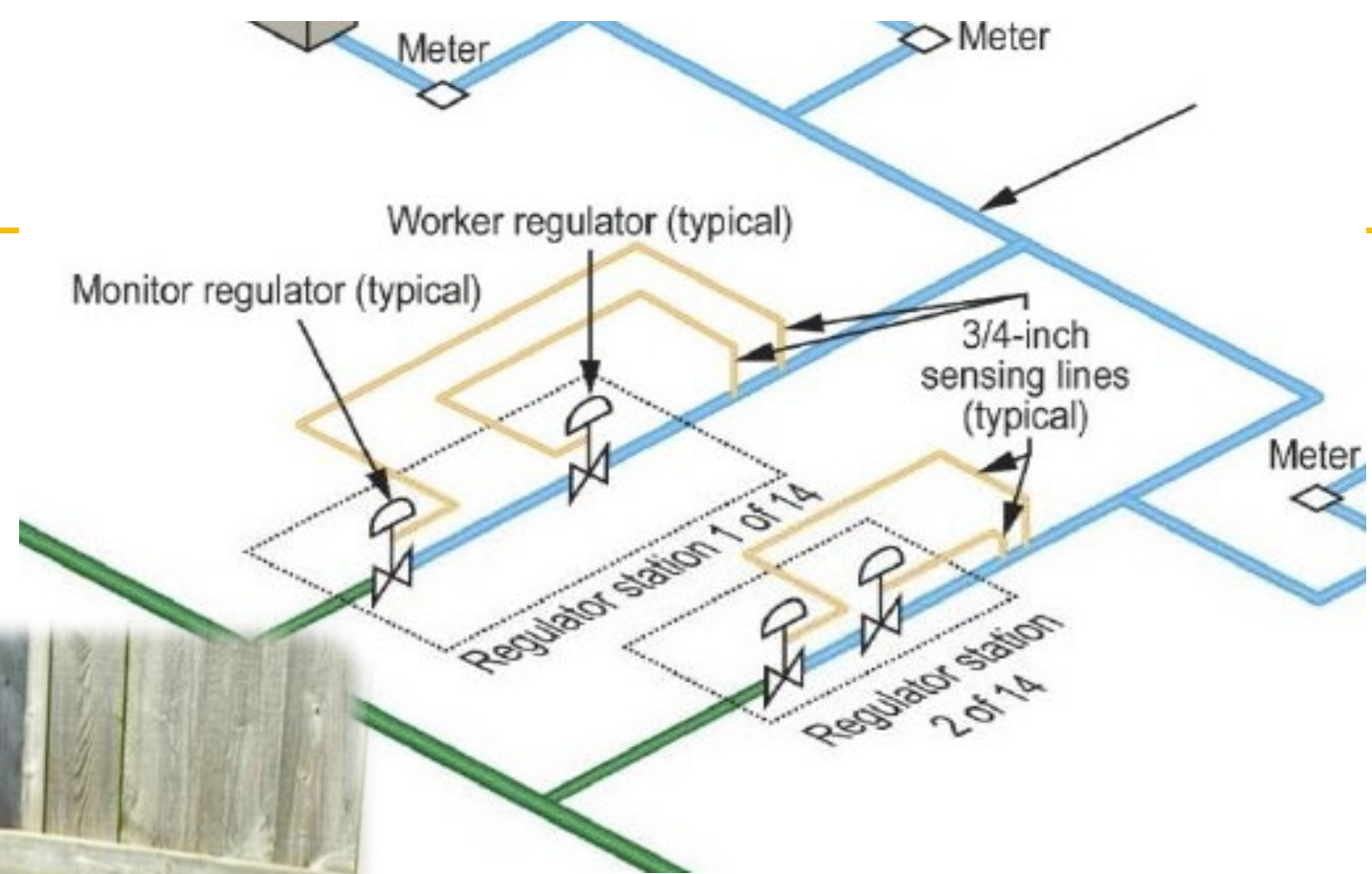

Regulator Station at Accident Site

- Sensing lines not mapped
- Abandoned 8" cast-iron main
- Regulators opened up

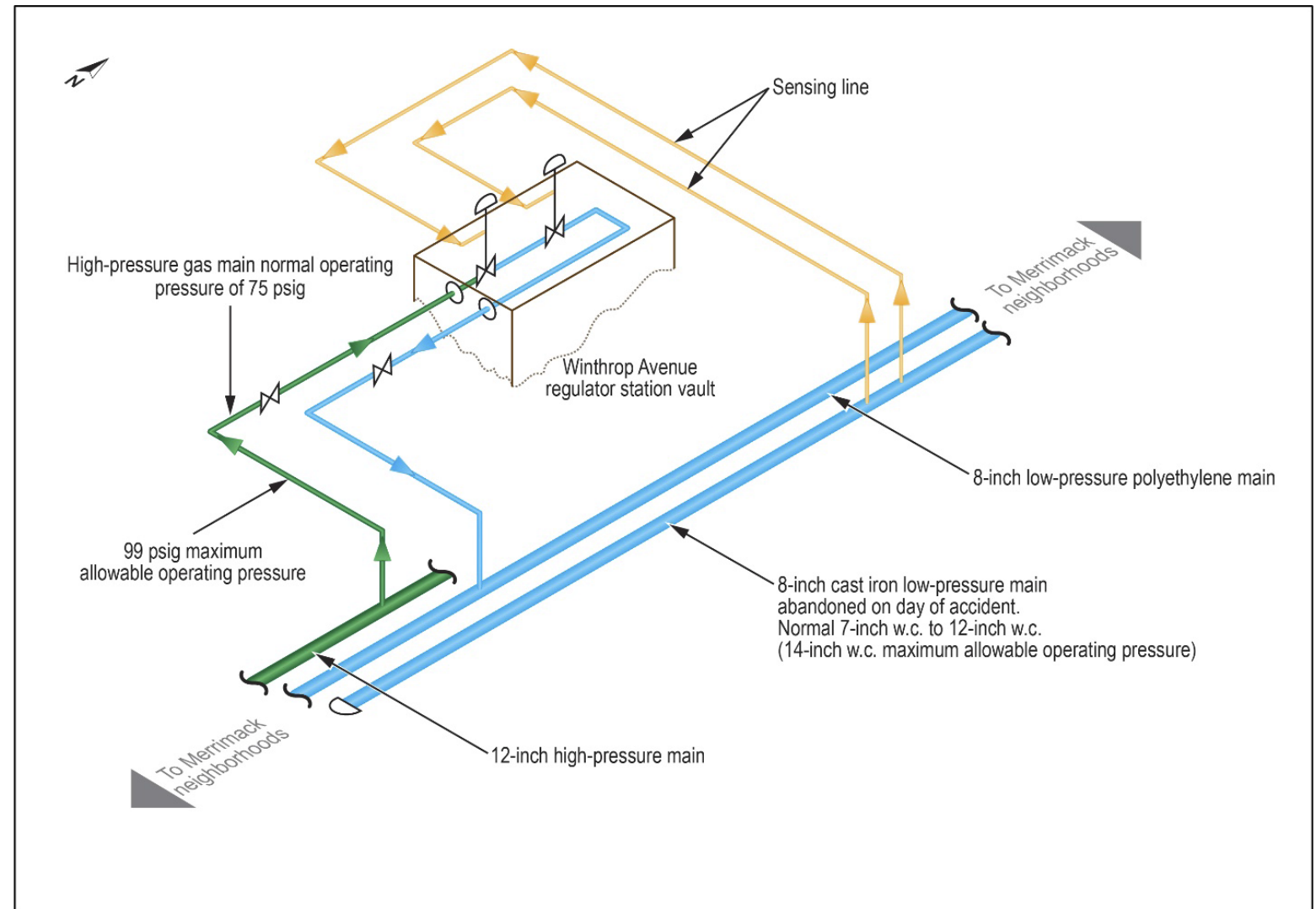

Leonel Rondon Act in the PIPES Act of 2020



1. Emergency Plans...

Modify the regulations to ensure that operators address establishing communications with first responders, as soon as practicable, from time of confirmed discovery..



NTSB/PAR-21/02

§60102(r)(1)



1. Emergency Plans...continued.

- Fire from unintended release
- Explosion
- Fatality
- Customers loss of service due to unscheduled release of gas

§60102(r)(1)

1. Emergency Plans...continued.



Establishing general public communication through an appropriate channels

- About the Emergency
- Status of Public Safety

§60102(r)(2)

2. O&M Plans

Modify the regulations to ensure that operators address the response to overpressure events and specific actions to be taken.

2. O&M Plans...Continued



Immediately reduce pressure or shut in when overpressurization happens.

2. Management of Change...



- Technology
- Equipment
- Procedural
- Organizational

§60102(s)(2)

2. Management of Change...Continued

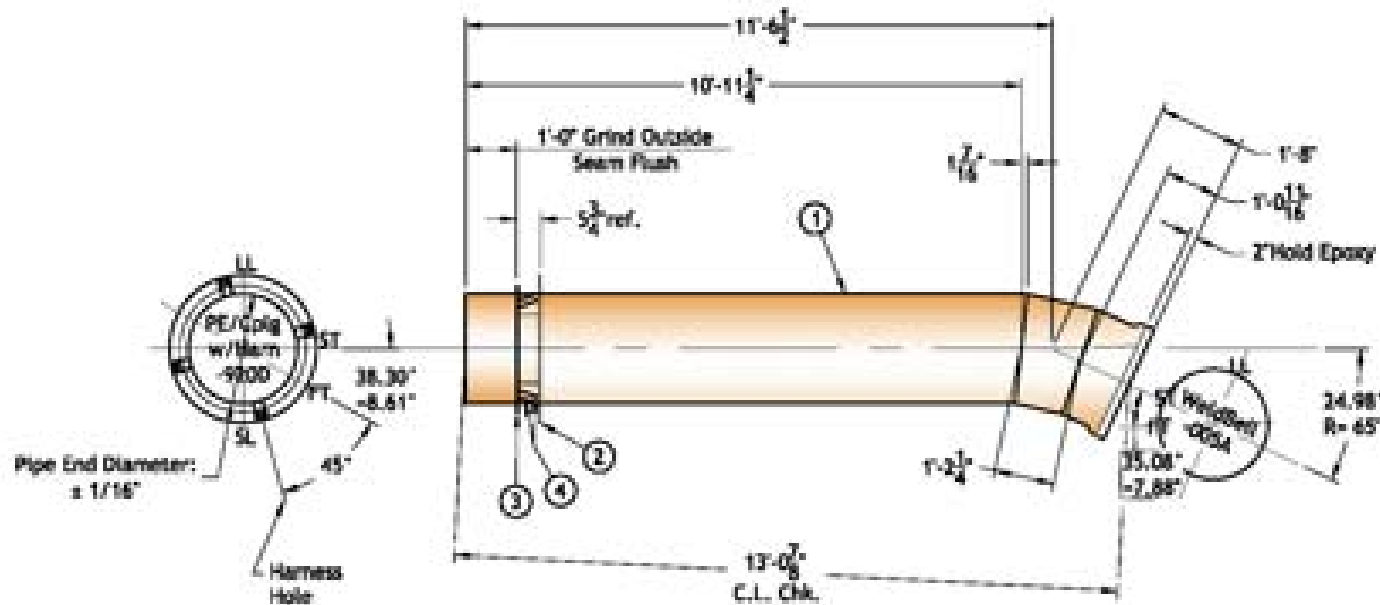

- Pipeline Design
- Construction

QUALIFIED

§60102(s)(2)

3. Other Pipeline Safety Practices

Identify and manage traceable, reliable, and complete records

- Pressure controls for Distribution
- Records to support Risk Analysis

§60102(t)(1)



3. Other Pipeline Safety Practices...Continued

Person to monitor pressure and promptly shut in, to control overpressurization.

§60102(t)(2)



3. Other Pipeline Safety Practices...Continued

Modify designs of pressure control equipment if necessary

§60102(t)(3)(A)



4. Risk of Cast Iron...

Modify the regulations to ensure that operators address Cast Iron in DIMP



§60109(e)(7)(A)

4. Low Pressure Systems

- Evaluate the risk of the overpressurization a low-pressure gas system.
- Identifying measures to address or mitigate the risk.

§60109(e)(7)(A)





Steven Kirkland
PHMSA Training &
Qualifications

Steven.Kirkland@dot.gov

405-423-1353