

PROJECT TITLE
BLACK ICE DETECTION AND ROAD CLOSURE CONTROL SYSTEM FOR OKLAHOMA

FINAL REPORT ~
[FHWA-OK-14-08](#)
ODOT SP&R 2249

REQUEST THE FINAL REPORT:
odot-library@ou.edu
<http://www.ou.edu/oktl>

INVESTIGATORS
Tieming Liu, Ph.D.,
Ning Wang, P.E.,
Hongbo Yu, Ph.D.
Oklahoma State University
Jeffrey Basara, Ph.D.,
Yang (Eric) Hong, Ph.D.,
The University of Oklahoma
Satish Bukkapatnam, Ph.D.,
Texas A&M University

ODOT SPONSORS
David Ooten, P.E.
State Research Engineer
Ron Curb, P.E., CPM,
Engineering Manager II

Office of Research & Implementation

Oklahoma Department of Transportation
200 NE 21st Street,
Oklahoma City, OK
73105-3204

Implementation of Research for Transportation Excellence

MORE INFORMATION
odot-spr@odot.org

BLACK ICE DETECTION AND ROAD CLOSURE CONTROL SYSTEM FOR OKLAHOMA

May 2016

OVERVIEW Black ice is a thin coating of glazed ice on roadways or other transportation surfaces. Black ice has identical appearance to wet, black pavement and is difficult to see. It usually forms at night or early morning, first on bridges and overpasses (due to their elevated nature and being exposed on all sides), then on the roads as temperatures continue to drop. Black ice is especially hazardous, causing numerous accidents in Oklahoma each year.

A major obstacle to implementation of a black ice detection and warning system is that current available sensors are too expensive. Therefore, one of the objectives of this project was to develop a functionally competent and economically feasible sensing system for black-ice detection by using regular temperature, humidity, and light sensors instead of expensive ice sensors. The sensors can be widely applied on bridges and overpasses at low cost to reduce ice-related accidents in Oklahoma.

RESULTS In this project, a prototype decision support system (DSS), illustrated in Figure 1, was developed to predict and detect black ice formation and pinpoint dangerous road sections. A wireless controlled module control would activate ice-warning and lane-closure signals and lights remotely.

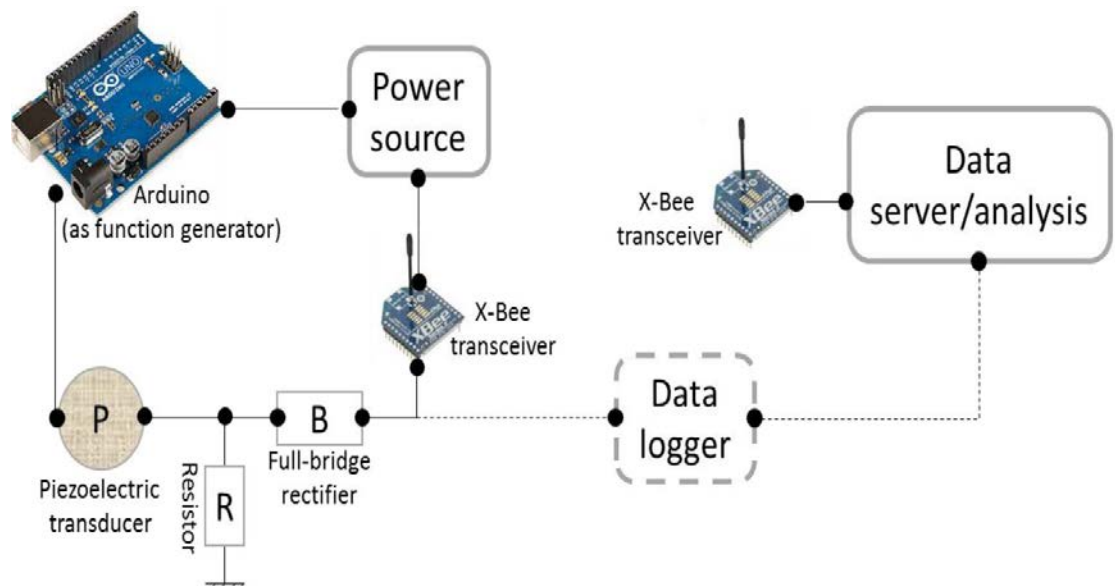

Figure 1 Overall system design of an automatic air, water and ice detection system

The study proved that the concept of using a piezoelectric transducer to distinguish between water and ice states was valid. The next consideration was how to design the whole working system to be automatic, compact, and low-cost.

This work demonstrated a novel approach for real-time detection of ice formation on roadways (Figure 2). The physical principle of the detection approach is based on discerning elastic stiffness and compliance changes associated with phase transformations. Off-the-shelf piezoelectric sensors, microprocessors and low-power wireless modules were employed to develop a cost-effective sensing unit capable of discerning the stiffness changes. The sensor was tested using a laboratory test-bed available in the Sensor Networks and Complex Systems (COMMSSENS) research lab at the Oklahoma State University. Signals from the wireless unit were processed at the base station computer for ice detection on different substrate materials pertinent to road highways. Several alternative statistical classification approaches were investigated, and the experimental studies suggest that a Gaussian Mixture Model (GMM) would be best suited for real-time detection of ice formation with adequate sensitivity and specificity (all > 90% under tested conditions).

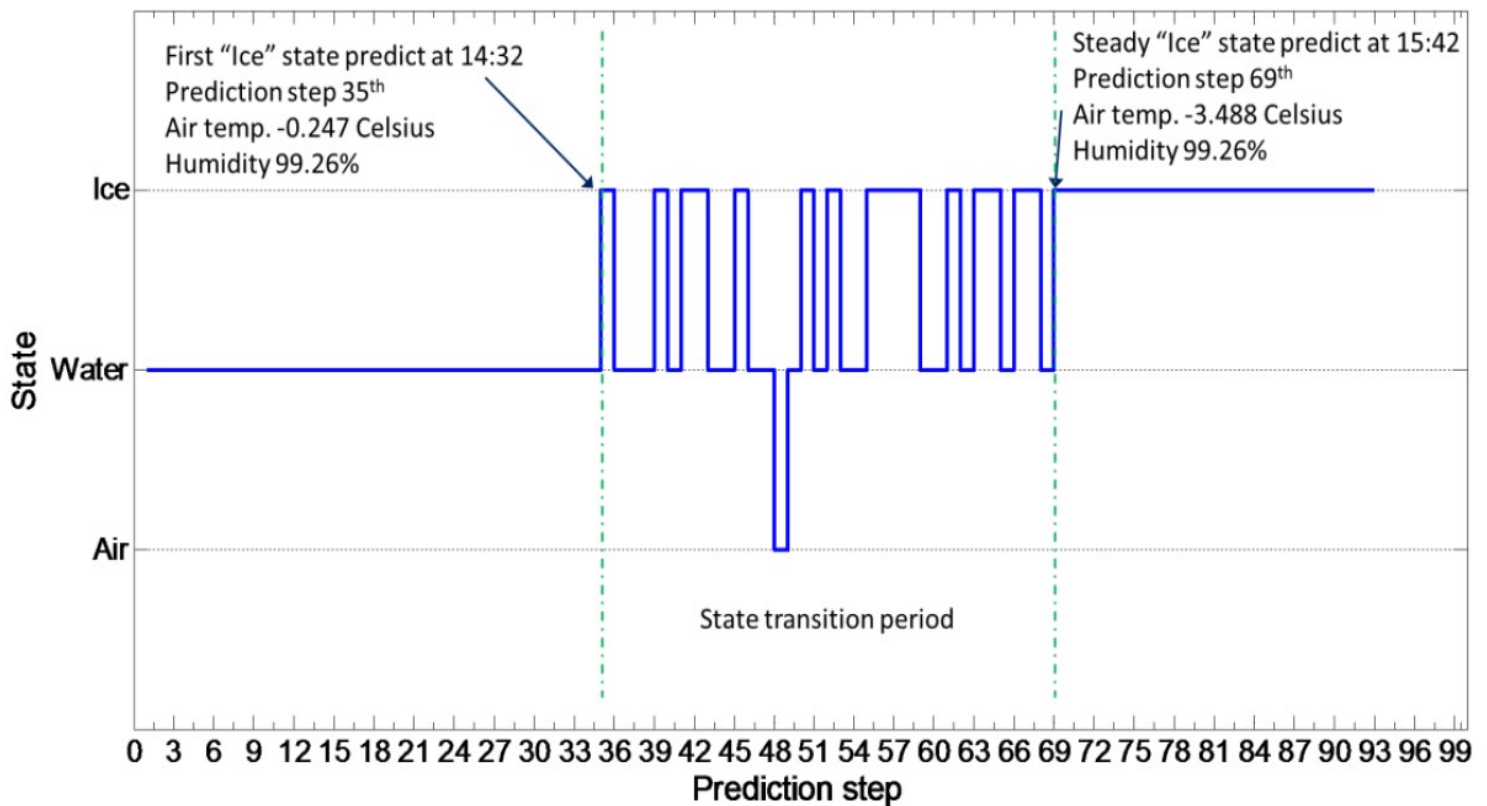

Figure 2 State prediction result from piezo sensor and model

A custom GIS interface was developed to support visual and spatial analysis for making road closure decisions under black ice emergencies. A custom toolset with add-in tools was created to help emergency management officers comprehend the data produced from the black ice prediction module and examine how the predicted black ice event will affect the roads, bridges and local communities. The toolset helps identify roads/bridges that are within the predicted black ice zones and likely to have black ice forming on the surface and should be closed to prevent potential accidents and loss of life.

Based on the results, we recommend additional laboratory studies involving phase transformations of water with different pH (and additives), on different substrates (concrete versus asphalt, with different surface topographies). Additionally, field tests on 2-3 bridges would be necessary to fully analyze the performance of the new approach.

POTENTIAL BENEFITS The decision support system (DSS) will cost much less than current systems, so it can be implemented statewide. The system will help Oklahoma Department of Transportation (ODOT) and other highway system response agencies make prompt and effective decisions to reduce the number of traffic accidents caused by ice.